

This drawing contains confidential technical data that is proprietary to PowerFlow Fluid Systems. The drawing, technical data, design rights and all other disclosures contained in this document are the property of PowerFlow Fluid Systems. Unauthorized use, copying, distribution to third parties, manufacture or reproduction in part or in whole is prohibited. All rights are reserved.

PORT MATRIX	
PORT ID	CONNECTION
IN1 - OU1	1" FEMALE NPT, SAE 37 DEG FLARE OR QUICK DISCONNECT. VARIES WITH OPTIONS CHOSEN AT TIME OF ORDER

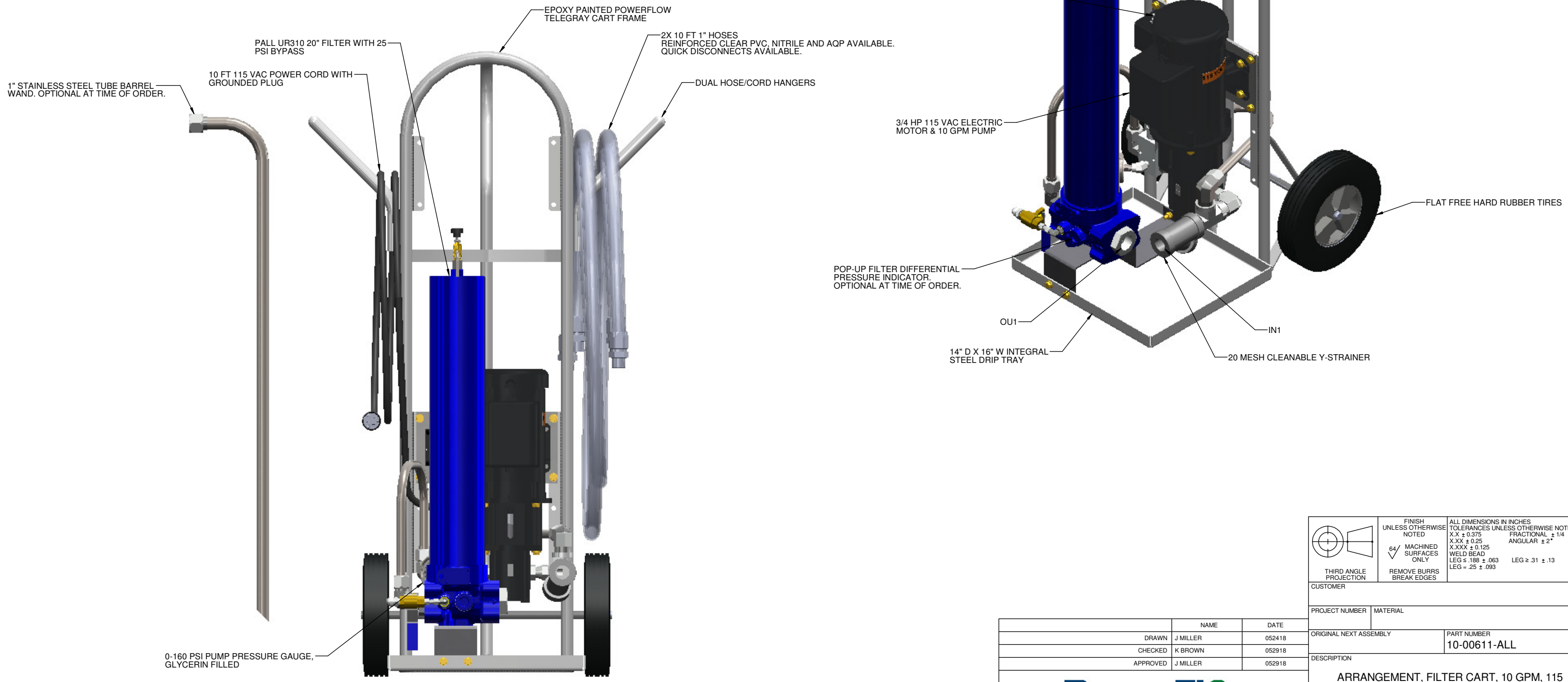
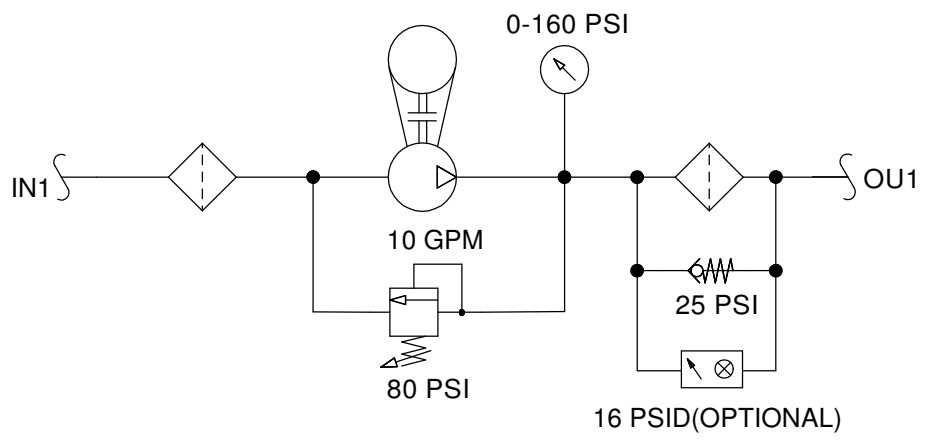

UNCONTROLLED DRAWING COPY
NOT TO BE USED FOR PRODUCTION

	NAME	DATE
DRAWN	J MILLER	052418
CHECKED	K BROWN	052918
APPROVED	J MILLER	052918



THIRD ANGLE PROJECTION		FINISH UNLESS OTHERWISE NOTED		ALL DIMENSIONS IN INCHES TOLERANCES UNLESS OTHERWISE NOTED	
64° MACHINED SURFACES ONLY		REMOVE BURRS BREAK EDGES		X.X ± 0.25 X.XXX ± 0.125 WELD BEAD LEG ≤ .188 ± .063 LEG = .25 ± .093	
CUSTOMER		PROJECT NUMBER		MATERIAL	
ORIGINAL NEXT ASSEMBLY		PART NUMBER		10-00611-ALL	
DESCRIPTION					
ARRANGEMENT, FILTER CART, 10 GPM, 115 VAC, PALL UR310 FILTER, FKM SEALS					
SHEET	SCALE	SIZE	DRAWING NUMBER	REV	
1 OF 1	NONE	D	AR10-00611		