



SRK Combo

Max Flow: 79 gpm (300 lpm)



## SRK Suction/Return Combination In-Tank Filters

### Working Pressures to:

145 psi / 1000 kPa / 10.0 bar

### Rated Static Burst to:

217 psi / 1497 kPa / 15.0 bar

### Flow Range To:

79 gpm / 300 lpm

### Applications

- Hydrostatic Transmissions
- Mobile Equipment

### Features

The SRK tank-mounted suction and return filter is a popular choice for hydrostatic transmissions. The filtered flow is maintained at a slight backpressure to provide clean, pressurized oil, mainly for charge pumps in hydrostatic transmission systems. The pressurized flow is designed to reduce cavitation risks. This patented design uses an integrated main flow and bypass flow filter, which is capable of delivering filtered and pressurized oil, even in bypass situations. Emergency suction flow is also filtered. The SRK operates in a standard flow (outside to inside) configuration. SAE O-Ring ports are standard to meet popular application requirements.

- 4-point mounting
- Head material: aluminum
- Housing material: steel
- Cover material: glass-filled nylon
- Nitrile seals standard
- Main filters include integrated bypass filters



### Beta Rating (per ISO 16889)

- Performance to  $\beta_{13(c)}=1000$

### Porting Size Options

- Inlet: SAE-16, SAE-20 O-Ring
- Outlet: SAE-16 O-Ring

### Replacement Filter Lengths

- 18.6" / 472mm

### Standard Bypass Ratings

- 36 psi / 250 kPa / 2.5 bar

### Standard Backpressure Ratings

- 7.3 psi / 50 kPa / 0.5 bar

### Assembly Weight

- 10.8 lbs / 4.9 kg

### Operating Temperatures

- -22°F to 212°F / -30°C to 100°C

### Filter Collapse Ratings

- 145 psid / 1000 kPa / 10 bar

### Return Flow Rate

- 79 gpm (300 lpm)

### Emergency Suction Flow Rate

- 27 gpm (100 lpm)

# SRK Filter Assemblies

Part No.	Inlet Port Connections	Outlet Port Connections	Bypass Valve	Emergency Suction	Comments
K041634	SAE-20 & SAE-16	(2) - SAE-16	36 psi (2.5 bar)	125 µm Wire Mesh	Indicator not included

## Filter Choices

Media Type	$\beta_{x(e)} = 1000$	Length		Part No.	Bypass	Comments
	Rating based on ISO 16889	in	mm			
Synteq Synthetic	13 µm	18.6	472	P765457	125 µm Wire	For Combo 300 Assemblies

Standard collapse designs are double wire-backed using epoxy-coated steel mesh for maximum pleat support and dirt capacity. All SRK filters are standard flow (outside to inside). Nitrile seals are standard on all SRK filters.

## Suction Filter Choices

Media Type	$\beta_{x(e)} = 2$	Length		Part No.
	Rating based on ISO 16889	in	mm	
Wire Mesh	125 µm	1.98	50.2	P764183

## Indicator Options

Part No.	Set Point	Style	Connection
P764467	36 psi (2.5 bar)	30 VDC, N.O.	G1/8"
P764613	36 psi (2.5 bar)	30 VDC, N.C.	G1/8"
P764612	36 psi (2.5 bar)	Visual	G1/8"

## ASSEMBLY - SIDE VIEW

All dimensions are shown in millimeters [inches].

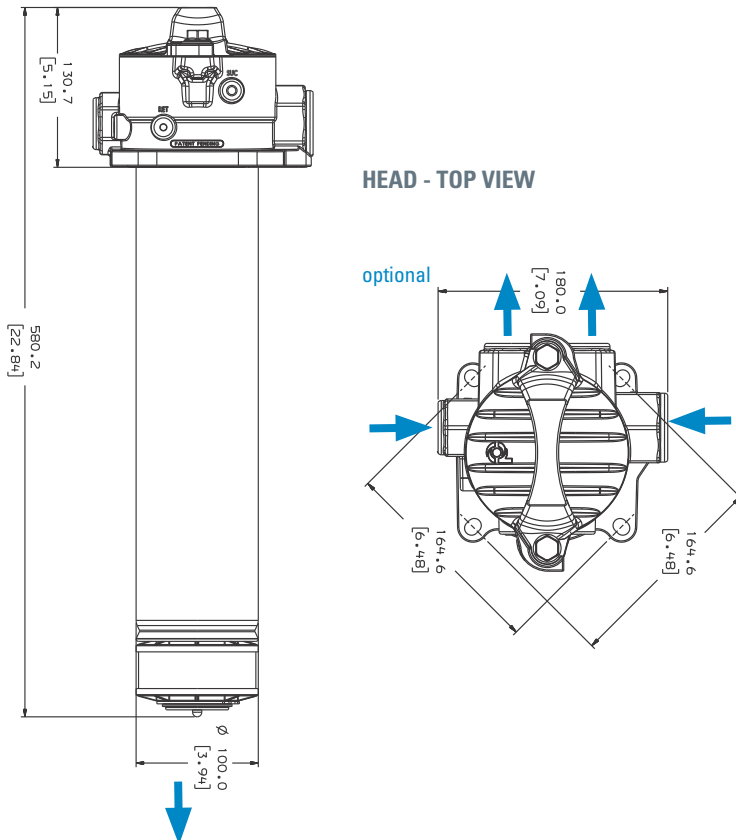

shop.donaldson.com

## Performance Data

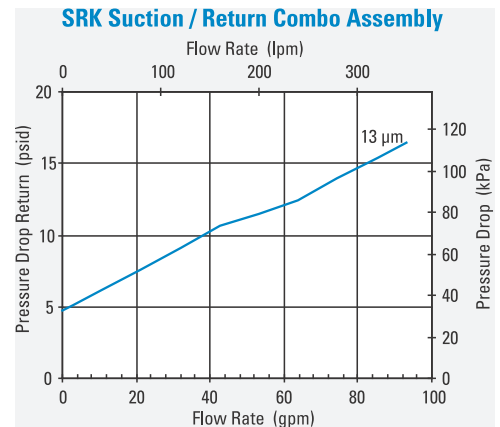

## Flow Schematic

