



SP100/120

Max Flow: 100 gpm (379 lpm)



## SP100/120 Spin-On Filters

### Working Pressures to:

150 psi / 1035 kPa / 10.3 bar

### Rated Static Burst to:

250 psi / 1725 kPa / 17.2 bar

### Flow Range To:

100 gpm / 379 lpm

### Features

SP100/120 double filter head allows for double the flow capacity and a unique, space-saving configuration. Aluminum casting and nitrile seals standard. SP100/120 filters are interchangeable with SP50/60 filters.

### Applications

- Fluid Conditioning Systems
- In-Plant Systems



### Beta Rating

- Performance to  $\beta_{<4(\mu)}=1000$

### Porting Size Options

- 1½" NPT

### Replacement Filter Lengths

- 6.7" / 170mm
- 7.0" / 178mm
- 10.7" / 271mm

### Standard Bypass Ratings

- 25 psi / 172.5 kPa / 1.72 bar

### Assembly Weight

- 7.0 lbs / 3.2 kg (short)
- 8.8 lbs / 4.0 kg (long)

### Operating Temperatures

- -22°F to 225°F / -30°C to 107°C

### Filter Collapse Ratings

- 100 psid / 690 kPa / 6.9 bar

## SP100/120 Specification Illustrations

### ASSEMBLY - SIDE VIEW

All dimensions are shown in inches [millimeters].

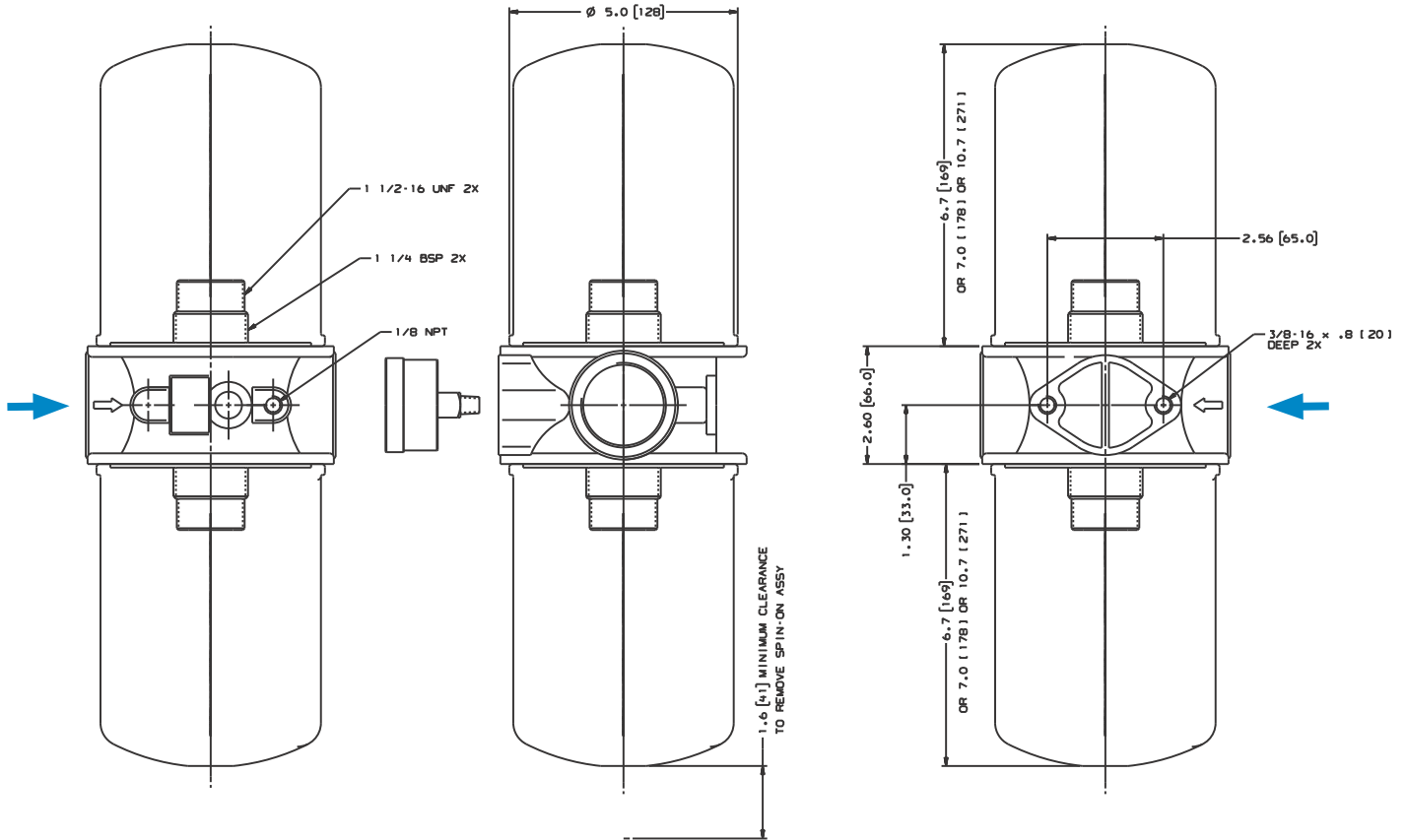



SP100/120

Max Flow: 100 gpm (379 lpm)



## SP100/120 Components

### Filter Choices

Media Type	$\beta_{x(c)} = 2$	$\beta_{x(c)} = 1000$	Length		Part No.	Comments
	Rating based on ISO 16889		in	mm		
Synteq Synthetic		<4 $\mu\text{m}$	10.7	271	P167796	Fluorocarbon O-Ring & square seal kit. Compatible with water glycol.
		6 $\mu\text{m}$	6.7	170	P167162	3-seal kit
		6 $\mu\text{m}$	10.7	271	P165762	3-seal kit
		11 $\mu\text{m}$	6.7	170	P165875	3-seal kit
		11 $\mu\text{m}$	10.7	271	P165876	3-seal kit
		13 $\mu\text{m}$	6.7	170	P167944	Fluorocarbon O-Ring & square seal kit. Compatible with water glycol.
		13 $\mu\text{m}$	10.7	271	P167945	Fluorocarbon O-Ring & square seal kit. Compatible with water glycol.
		23 $\mu\text{m}$	6.7	170	P165877	3-seal kit
		23 $\mu\text{m}$	10.7	271	P165878	3-seal kit
		50 $\mu\text{m}$	6.7	170	P165879	3-seal kit
		50 $\mu\text{m}$	10.7	271	P165880	3-seal kit
Cellulose	5 $\mu\text{m}$		6.7	170	P550386	3-seal kit
	5 $\mu\text{m}$		10.7	271	P550250	3-seal kit
	7 $\mu\text{m}$		6.7	170	P550388	3-seal kit
	7 $\mu\text{m}$		10.7	271	P550251	3-seal kit
	7 $\mu\text{m}$		7.00	178	P565245	Square seal kit, 1/4" BSP thread
	17 $\mu\text{m}$		6.7	170	P550387	3-seal kit
	17 $\mu\text{m}$		10.7	271	P550252	3-seal kit
	27 $\mu\text{m}$		7.00	178	P171616	Square seal kit, 1/4" BSP thread
Water Absorbing	10 $\mu\text{m}$		10.7	271	P561183	Cellulose media, 3-seal kit. Absorbs 350 ml water.
Wire Mesh	150 $\mu\text{m}$		6.7	170	P550275	Stainless steel wire mesh, 3-seal kit
	150 $\mu\text{m}$		10.7	271	P550276	Stainless steel wire mesh, 3-seal kit

All models have 1/2-16 UNF threads except where otherwise noted. All models measure 5.0"/127mm outer diameter.

### Head Choice

Port Size	Bypass Rating	Gauge Ports (drill, tap, plug)	Gauge Port Location	Part No.
1/2" NPT	25 psi / 172.5 kPa / 1.72 bar	(2) 1/8" NPT	upstream & downstream sides	P563277

Note: On a return line system the gauge port should be on the upstream side. We suggest a 25 psi bypass. If head is used on a suction line, the gauge port should be on the downstream side very low bypass.

### Gaskets

Each filter ships with a 3-seal kit, containing an "L" shaped, a square cut, and an O-Ring gasket seal, unless otherwise noted. Use only one of the following seals. Installation instructions can be found in the technical reference section.

- L Shaped  
Use with filter heads with no groove or a wide groove.
- Square Cut  
Use with filter heads with a narrow groove.
- O-Ring -246  
Use with Donaldson HBK05 heads only.

## Optional Filter Service Indicators

This handy pressure gauge, mounted on the side of an SP100/120 filter head, will tell you when it's time to service the filter.

Part No.	Pressure Range	Use With Bypass Valve Rating	Type
P563978	5 to 30 psi field adj.*	15 psi / 103.4 kPa / 1.34 bar or 25 psi / 172.5 kPa / 1.72 bar or No Bypass	Return indicator, electrical
P563979	-5 to 15 in Hg field adj.*	5 psi / 34.5 kPa / .34 bar or No Bypass	Suction indicator, electrical
P579714	0 to 100 psi	15 psi / 103.4 kPa / 1.34 bar or 25 psi / 172.5 kPa / 1.72 bar or No Bypass	Return indicator, numeric scale
P579715	0 to 100 psi	15 psi / 103.4 kPa / 1.34 bar Bypass	Return indicator, color coded
P579716	0 to 100 psi	25 psi / 172.5 kPa / 1.72 bar or No Bypass	Return indicator, color-coded
P579717	0 to -30 Hg	5 psi / 34.5 kPa / .34 bar or No Bypass	Suction indicator, numeric scale

**P563978**

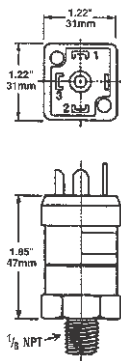

**P563979**

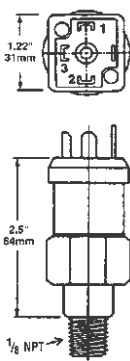

#1 Common; #2 Normally Closed; #3 Normally Open

**Instructions**

1. Remove DIN adaptor
2. Remove small brass screw
3. Using 1/8" allen wrench adjust clockwise to increase set point/counter-clockwise to decrease set point
4. NO / NC

Adjustment screw located in center of electric prongs

**P579714 - P579717**

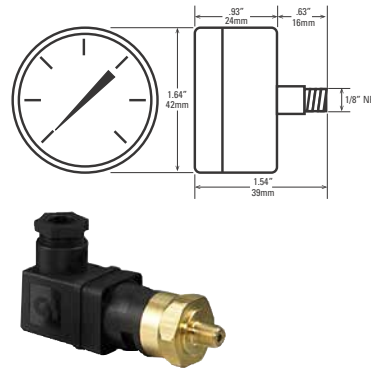

**Notes**

\* NOT PRESET: Setting adjustable for desired application

## Performance Data

