



HBK05

Max Flow: 60 gpm (227 lpm)



HBK05 Spin-On Filters

Working Pressures to:

150 psi / 1035 kPa / 10.3 bar

Rated Static Burst to:

250 psi / 1725 kPa / 17.2 bar

Flow Range To:

60 gpm / 227 lpm

Applications

- Cooling Circuits
- Fluid Conditioning Systems
- Hydrostatic Charge Pumps
- Lube Oil Systems
- Power Transmissions
- Return Lines
- Side Loop Systems

Features

HBK05 is a strong and durable low pressure filter with a spin-on design that simplifies servicing and reduces maintenance costs. Its heavy-duty steel canister has a rigid steel attachment plate for added strength. The head-to-canister O-Ring seal is designed to ensure seal integrity beyond 250 psi/17 bar. The head is made of die-cast aluminum.

Take advantage of our mix and match system of in-stock heads and filters — so you can get exactly what you need, HBK05 is available with your choice of visual or electrical service indicators, and bypass ratings of 50 psi, 25 psi, or 5 psi. The filter media is Synteq™, our proprietary synthetic media specifically designed for liquid filtration.

HBK05 filters ship with "L", square, and O-Ring gaskets (unless noted with fluorocarbon seals, then with square and O-Ring gaskets). All HBK05 filters are interchangeable with SP50/60, SP80/90 and SP100/120 spin-ons, and have 1½" - 16 UN threads.



Beta Rating

- Performance to $\beta_{<40} = 1000$

Porting Size Options

- 1¼" NPT
- SAE-20 O-Ring

Replacement Filter Lengths

- 6.7" / 170mm (short)
- 10.7" / 271mm (long)

Standard Bypass Ratings

- 50 psi / 345 kPa / 3.4 bar
- 25 psi / 172.5 kPa / 1.7 bar
- 5 psi / 34.5 kPa / .34 bar

Assembly Weight

- 6.9 lbs / 3.1 kg (long)
- 5.7 lbs / 2.6 kg (short)

Operating Temperatures

- -22°F to 225°F / -30°C to 107°C

Filter Collapse Ratings

- 125 psid / 863 kPa / 8.6 bar

HBK05 Specification Illustrations

ASSEMBLY - SIDE VIEW

All dimensions are shown in inches [millimeters].

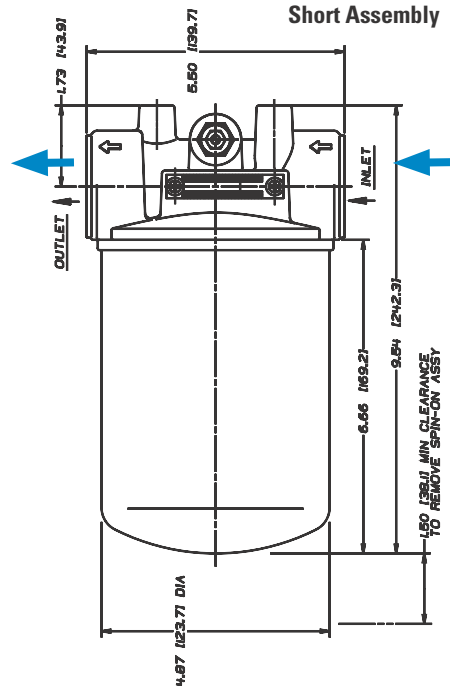
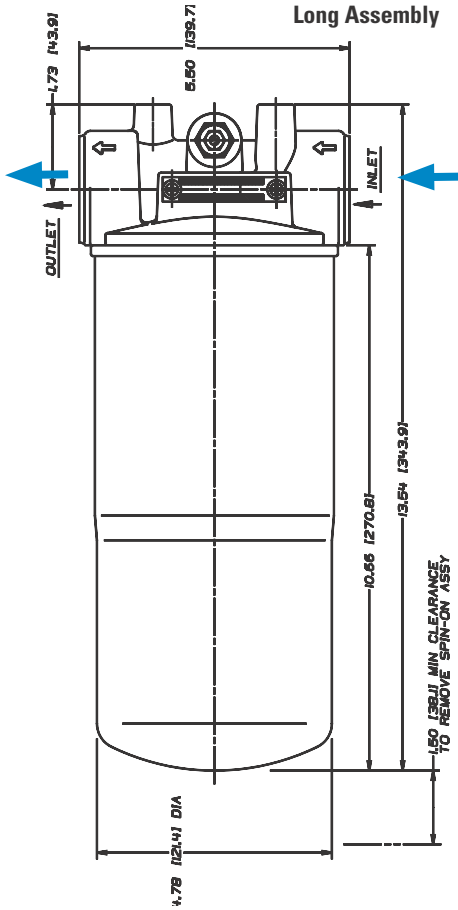

HEAD - TOP VIEW

with DC Electrical Service Indicator

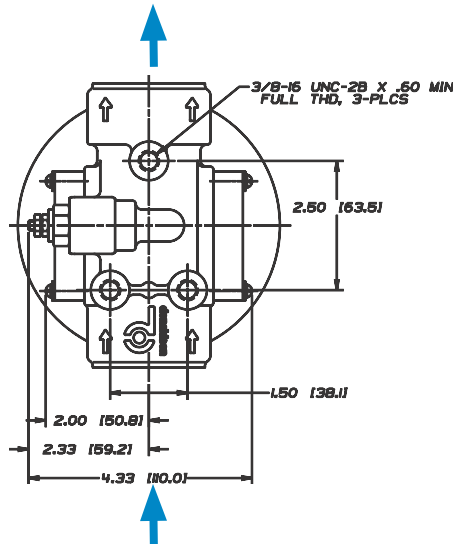

with AC/DC Electrical Service Indicator

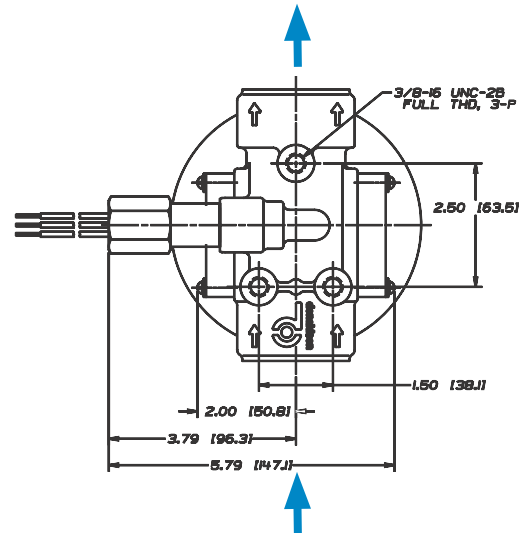

HBK05 Components

Filter Choices

Media Type	$\beta_{x(C)} = 2$	$\beta_{x(C)} = 1000$	Length		Part No.	Comments
	Rating based on ISO 16889		in	mm		
Synteq Synthetic		<4 μm	10.7	271	P167796	Fluorocarbon seal. Compatible with water glycol.
		6 μm	6.7	170	P167162	
		6 μm	10.7	271	P165762	
		11 μm	6.7	170	P165875	
		11 μm	10.7	271	P165876	
		13 μm	6.7	170	P167944	Fluorocarbon seal. Compatible with water glycol.
		13 μm	10.7	271	P167945	Fluorocarbon seal. Compatible with water glycol.
		23 μm	6.7	170	P165877	
		23 μm	10.7	271	P165878	
		50 μm	6.7	170	P165879	
		50 μm	10.7	271	P165880	
Water Absorbing	10 μm		10.7	271	P561183	Cellulose media, 3-seal kit. Absorbs 350 ml water.

Filter Notes: * Thread size 11/2"-16 UN.

Head Choices

Port Size	Bypass Rating	Indicator Style & Location	Part No.
1/4" NPT	50 psi / 345 kPa	Visual, Both Sides	P172953
1/4" NPT	25 psi / 172 kPa	Visual, Both Sides	P166418
1/4" NPT	5 psi / 34 kPa	Visual, Both Sides	P166665
SAE-20 O-Ring	25 psi / 172 kPa	Visual, Both Sides	P166439

Note: *Donaldson uses the inlet port as the reference point. "Left side," for instance, means that the indicator mounts on the side of the filter head that is on your left when you face the inlet port.

Service Indicator Options

Use with Bypass Valve Pressure of:	Indicator Part No.	Style ⁽³⁾	Description
Electric Models⁽¹⁾			
5 psi / 34.5 kPa	P163642	A	Single post DC. Normally open.
15 psi / 103 kPa	P163601	A	Single post DC. Normally open.
25 psi / 172.5 kPa	P163839	A	Single post DC. Normally closed.
25 psi / 172.5 kPa	P162400	A	Single post DC. Normally open.
25 psi / 172.5 kPa	P171143	B	2-wire with Cannon connector. Normally open.
25 psi / 172.5 kPa	P173944	C	3-wire: White = normally open. Red = normally closed. Black = common
50 psi / 276 kPa	P574967	E	DC 2-wire. Normally closed. Gold contacts. Microprocessor compatible.

Service Indicator Options

Use with Bypass Valve Pressure of:	Indicator Part No.	Style ⁽³⁾
Visual Models⁽²⁾		
5 psi / 34.5 kPa	P162694	D
15 psi / 103 kPa	P162642	D
25 psi / 172.5 kPa	P162696	D
N/A	P165984	(blank plate)
25 psi / 172.5 kPa	P575334	H (Visual pop up)
50 psi / 345 kPa	P575335	H (Visual pop up)



Mix and Match

Donaldson's mix and match system provides the great performance and functional advantages of custom-engineered filters with the convenience and speedy delivery of in-stock parts. Choose your options and build an HBK05 filter to suit your specifications.

Indicator Notes: ⁽¹⁾All electric models have a maximum operating temperature of 250°F/ 121°C.

⁽²⁾All visual models have a maximum operating temperature of 180°F/ 82°C. ⁽³⁾See indicator illustrations on facing page.

HBK05 Service Parts

SERVICE PARTS NOTE:
Some service parts may not be stocked. Please contact your Donaldson sales representative for lead time details.

Service Indicator Styles
(See table on opposite page)

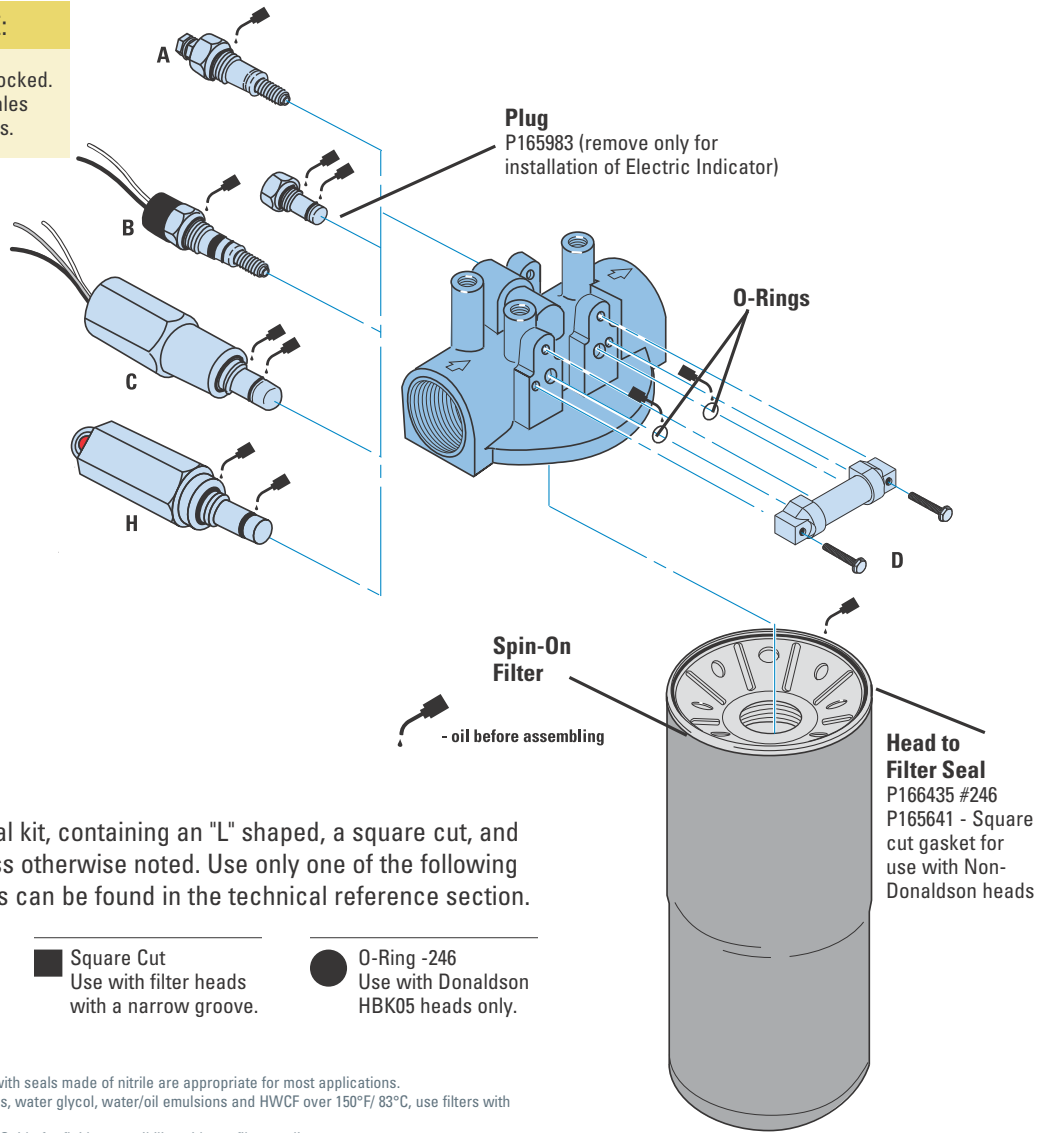

Gaskets

Each filter ships with a 3-seal kit, containing an "L" shaped, a square cut, and an O-Ring gasket seal, unless otherwise noted. Use only one of the following seals. Installation instructions can be found in the technical reference section.

- L Shaped**
Use with filter heads with no groove or a wide groove.
- Square Cut**
Use with filter heads with a narrow groove.
- O-Ring -246**
Use with Donaldson HBK05 heads only.

Filter Notes

- If you're filtering petroleum-based oil, filters with seals made of nitrile are appropriate for most applications.
- If you're filtering diester, phosphate ester fluids, water glycol, water/oil emulsions and HWCF over 150°F/ 83°C, use filters with seals made of fluorocarbon.
- Refer to the table in the Technical Reference Guide for fluid compatibility with our filter media.

Performance Data

